

250-10-PV DC SST

DC transformer for photovoltaic applications
with an optional MPPT module

SuperGrid Institute develops and markets advanced grid technologies to meet tomorrow's demands and support your future growth.

The DCSST-250-10-PV DC solid state transformer for photovoltaic applications offers developers the opportunity to use medium voltage DC collector networks. This transformer operates silently at medium frequency (>10 kHz).

The equipment provides galvanic isolation between the PV field and the MVDC collector network.

Designed with the power rating adapted for linear PV power plants, it is also perfectly adaptable for other applications. Designed with a high voltage ratio, it provides high efficiency and maximises energy delivery.



BLOCK DIAGRAM

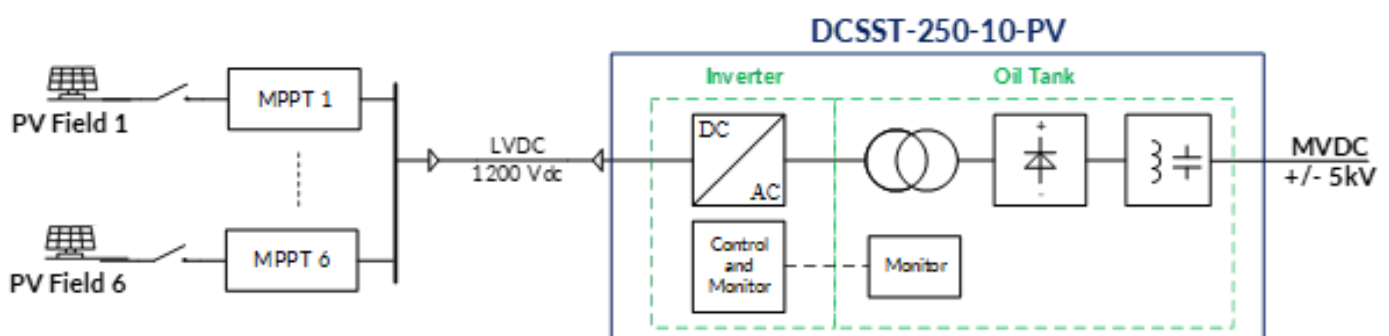

TECHNICAL CHARACTERISTICS OF THE DCSST-250-10-PV

EFFICIENCY

European efficiency at 20°C	>99%
Peak efficiency	>99,2%

INPUT (DC)

Nominal/Maximum Input Voltage	1,200/1,500 V
Maximum Input Power	250 kW at 50°C

OUTPUT (DC)

Output Configuration	Symmetrical Monopole
Nominal Output voltage, differential	10,000 V
Nominal/Maximum Output Current	25/28 A

DIMENSIONS AND WEIGHT

Width/Height/Depth, mm (W/H/D)	800/1550/1350
Weight	< 1,500 kg

GENERAL

Ambient temperature range	+5 ... +50 °C
Degree of protection, Oil Tank/Inverter	IP3x/IP2x
Communication interface	1 port Ethernet
Cooling, Oil tank/Inverter	Air/Forced Air
MVDC insulation level, IEC62271-5 ($U_{typ,d}$ / U_{dd} / U_p)	6 / 15/40 kV
Transformer insulation level, IEC60076-3 (U_m /AV/LI)	12/28/75 kV
Oil tank monitoring	Temperature, pressure, oil level

HIGH EFFICIENCY MPPT MODULE

Very high efficiency maximum power point tracking (MPPT) module to be used with the DC transformer to achieve an improved energy yield of PV power plants. Up to 6 MPPT units can be used with a single DCSST-250-10-PV transformer.

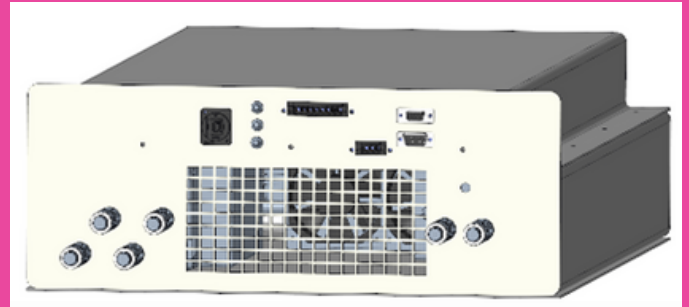

TECHNICAL CHARACTERISTICS of the PPT module

EFFICIENCY

European efficiency at 20°C	>99,5 %
Peak efficiency	>99.6 %

INPUT (DC)

Maximum Input Voltage	1,500 V
Operating Voltage Range	600 ... 1,175 V
Nominal Input Voltage	1,000 V
Maximum Input Power	50 kW at 50°C

OUTPUT (DC)

Nominal/Maximum Output voltage	1,200/1,500 V
--------------------------------	---------------



Contact:

For additional information or to ask for a quote, please contact:

camille.prudhomme@supergrid-institute.com

DISCLAIMER

Copyright © 2025 SuperGrid Institute SAS. All rights reserved. This document refers to the product under development. SuperGrid Institute makes no warranties or representations as to the information contained herein, including, but not limited to, its accuracy, the absence of potential errors, or any lack of information. The information is provided 'as is'. SuperGrid Institute accepts no liability whatsoever arising from the use of this document and the information contained herein. SuperGrid Institute reserves the right to make technical changes or modifications to the contents of this document without prior notice.

Shaping power transmission

SuperGrid Institute SAS – 23 rue Cyprien 69100 Villeurbanne, France
+33 4 28 01 23 23 - accueil@supergrid-institute.com - www.supergrid-institute.com